

FORM NCR 102

**SPECIFICATIONS
FOR
PIPELINE OCCUPANCY
OF
NORTH CAROLINA RAILROAD COMPANY
PROPERTY**

**Revised
JANUARY 2005**

INDEX

		<u>PAGE No.</u>
1.0	GENERAL	
1.1	Scope	1
1.2	Definitions	1
1.3	Application for Occupancy	1
1.4	Right of Entry	2
1.5	Site Inspection	2
1.6	Information Required for Submission	3
1.7	Notification to Proceed with Construction	4
2.0	GENERAL REQUIREMENTS	
2.1	Use of a Casing Pipe	4
2.2	Location of Pipeline on the Right-of-Way	4
2.3	Depth of Installation	5
2.4	Pipelines within Limits of a Dedicated Highway	6
2.5	Modification of Existing Facilities	6
2.6	Abandoned Facilities	6
2.7	Conflict of Specifications	6
2.8	Insulation	6
2.9	Corrosion Protection and Petroleum Leak Prevention	6
3.0	SOIL INVESTIGATION	
3.1	General	7
3.2	Location	7
3.3	Sampling	7
3.4	Boring Logs	7
3.5	Additional Information	8
4.0	DESIGN REQUIREMENTS	
4.1	Design Loads	8
4.2	Design Assumptions	9
4.3	Casing Pipe	10
4.4	Carrier Pipe	13
4.5	Casing Pipe End Seals	15
4.6	Vents	15
4.7	Signs	15
4.8	Warning Tape	16
4.9	Shut-off Valves	16
4.10	Cathodic Protection	16
4.11	Manholes	16
4.12	Box Culverts	16
4.13	Drainage	17
4.14	Pipelines on Bridges	17

5.0 CONSTRUCTION REQUIREMENTS

5.1	Method of Installation	18
5.2	Grouting	21
5.3	Soil Stabilization	21
5.4	Dewatering	22
5.5	Safety Requirements	22
5.6	Blasting	22
5.7	Temporary Track Supports	22
5.8	Protection of Drainage Facilities	23
5.9	Support of Excavation Adjacent to Track	23
5.10	Inspection and Testing	24
5.11	Reimbursement of Railroad Costs	24

APPENDIX

PLATE I	Pipe Data Sheet	25
PLATE II	Plan (crossing)	26
PLATE III	Profile (crossing)	27
PLATE IV	Plan & Profile (longitudinal occupancy)	28
PLATE V	Section (longitudinal occupancy)	29
PLATE VI	Plan & Section (highway crossing under RR bridge)	30
PLATE VII	Elevation & Section (pipe on highway bridge over RR)	31
PLATE VIII	Test Boring Log	32
PLATE IX	Lateral Pressure Diagram	33
PLATE X	Folding of Plans	34
PLATE XI	Sample Weatherproof Sign	35
	Publication Standards Sources	36

Specifications For Pipeline Occupancy Of North Carolina Railroad Company Property

1.0 GENERAL

1.1 Scope

- A. This specification shall apply to the design and construction of pipelines carrying either flammable or non-flammable substances and casings containing either wires and/or cables across and along North Carolina Railroad Company (NCRR) property and facilities. This specification shall also apply to tracks owned by others (sidings, industry tracks, etc.) connected to NCRR and used by the Operating Railroad.
- B. It is to be clearly understood that NCRR owns its right-of-way for the primary purpose of railroad operations. All occupancies shall therefore be designed and constructed so that operations and facilities are not interfered with, interrupted or endangered. In addition, the proposed facility shall be located to minimize encumbrance to the right-of-way so that railroad will have unrestricted use of its property for current and future operations.

1.2 Definitions

- A. NCRR - North Carolina Railroad Company
- B. Operating Railroad - A railroad company designated by NCRR to operate trains on its property, currently, Norfolk Southern Corporation and in some places CSX Transportation (CSXT).
- C. Engineering Representative - Person or persons designated by NCRR to review and approve plans for pipeline occupancies of its property. Currently HNTB North Carolina, P.C.
- D. Owner (Applicant) - Individual, corporation or municipality desiring occupancy of NCRR property.
- E. Professional Engineer - Engineer licensed in North Carolina.
- F. Carrier Pipe - Pipe used to transport the product.
- G. Casing Pipe - Pipe through which the carrier pipe is installed.
- H. Sidings or industry tracks - Tracks located off NCRR's right-of-way, serving an industry.

1.3 Application For Occupancy

- A. Corporations or municipalities desiring occupancy of NCRR property by pipeline occupations must agree, upon approval of the engineering and construction details by the Engineering Representative, to execute an appropriate NCRR occupational agreement and pay any required fees and/or rentals specified therein. Applications will be accepted from the Owner or his designated representative, herein after referred to as the Applicant.
- B. The application for an occupancy shall be by application addressed to the Engineering Representative, HNTB North Carolina, P.C., 343 E. Six Forks Road, Suite 200, Raleigh, North Carolina 27609, attn. Manager, NCRR Pipes and Wires Occupancy Agreement Process. Provide information requested on the Application Forms including the following:
 - 1. Full name of Owner.
 - 2. Complete mailing address of the applicant.

3. Name and title of person who will sign the agreement.
4. Name of representative or contact person who will handle the request.
5. The State in which the applicant is incorporated.

- C. Applications shall only be made on the forms provided by the North Carolina Railroad. Contact the Engineering Representative at the above address for instructions, forms and further information. Application forms, instructions and specifications may also be obtained on the NCRR website (www.ncrr.com).
- D. All applications for the proposed occupancy shall be submitted in three (3) copies. Applications shall be accompanied with six (6) copies of all design and construction plans and three (3) copies of all specifications and engineering computations for the proposed occupancy. On extensive projects, only those plans involving work on, or affecting NCRR property and operations, shall be submitted. Included shall be a plan showing the extent of the total project upon which that portion of the work affecting NCRR is clearly defined.
- E. All of the above plans, specifications and computations must be prepared by and bear the seal of a Professional Engineer.

1.4 Right Of Entry

- A. No entry upon NCRR property for the purpose of conducting surveys, field inspections, obtaining soils information or any other purposes associated with the design and construction for the proposed occupancy, will be permitted without a proper entry permit prepared by the Engineering Representative. The applicant must pay the associated fees, if any, and execute the entry permit. An entry permit must also be obtained from the Operating Railroad.
- B. It is to be clearly understood that the issuance of an entry permit does not constitute authority to proceed with any construction. Construction can not begin until a formal agreement is executed by NCRR and the Owner receives permission from the Engineering Representative and the Operating Railroad to proceed with the work.

1.5 Site Inspection

- A. For longitudinal occupancy of NCRR property a site inspection along the proposed pipeline route may be required before final design plans are prepared. When a site inspection is required, the applicant and/or his engineer must meet with the Engineering Representative to view the entire length of the proposed occupancy.
- B. Prior to the site inspection the applicant must submit the following information:
1. A plan view of the proposed route showing all tracks, both NCRR right-of-way lines and all other facilities located on the right-of-way. The distance from the proposed pipeline to both the adjacent track and the right-of-way lines must be shown.
 2. A complete "Pipe Data Sheet" (See Plate I)
 3. Typical cross sections along the proposed route. (See Plate V)
- C. Site inspections for pipe crossings are not required unless, in the opinion of the Engineering Representative, the size and location of the facility warrant an inspection.

1.6 Information Required for Submission

1.6.1 Plans and Computations

- A. Plans for proposed pipeline occupancies shall be submitted to the NCRR Engineering Representative and approved by the Engineering Representative prior to NCRR issuing an Occupancy Agreement and the start of construction.
- B. Plans are to be prepared in sizes that may be folded, individually, by the applicant to an 8 ½ inch by 11 inch size, as shown on Plate X, prior to submission. Where more than one plan is involved, the folded plans shall be assembled into complete sets by the applicant before submission. Failure of the applicant to comply with these requirements may be sufficient cause for rejection of the application.
- C. Plans shall be drawn to scale and shall include the following (See Plates I to VII)
1. Plan view of proposed pipeline in relation to all NCRR facilities and facilities immediately adjacent to NCRR including, but not limited to, tracks, buildings, signals, pole lines, other utilities and all other facilities that may affect or influence the pipeline design and construction. (See Plate II)
 2. The location, in feet, of the pipe crossing from the nearest NCRR Milepost and/or from the centerline of a NCRR bridge, giving the NCRR bridge number. If the above is not available, provide distance to the nearest highway grade crossing of the railroad. The AAR/DOT number of the grade crossing should be indicated on the plans. The number is on a metal tag located on the cross buck or flasher post in the format 123 456B.(See Plate II)
 3. In all cases, the name of the City/Town and County in which the proposed facilities are located must be shown.
 4. The profile of the ground above the centerline of the pipe, from field survey, showing relationship of the pipeline and/or casing pipe to the ground levels, the tracks and other facilities, (See Plate III). For longitudinal occupations, the top of rail profile of the adjacent track shall be shown on the pipeline profile, (See Plate IV)
 5. All NCRR property lines indicated by dimensions, in feet, to the centerline of adjacent track, as well as the overall width of the NCRR right-of-way. If the pipeline is in a public highway, the limits of the dedicated highway right-of-way, as well as the limits of any paving, sidewalks etc., shall be defined, by dimensions in feet, from the centerline of the dedicated right-of-way. (See Plate II)
 6. The angle of the crossing in relation to the centerline of the track(s). (See Plate II)
 7. On pipelines having valves, the distance in feet along the pipeline from the crossing to the nearest valves and/or control stations
 8. A separate "Pipe Data Sheet" (See Plate I) shall be submitted on an 8 1/2 inch by 11 inch sheet, for each crossing.
- D. For all installations on NCRR property and under tracks that are not on NCRR property but are used by the operating railroad (i.e. industry tracks), the plans shall be specific as to the:
1. Method of installation.
 2. Size and material of the casing pipe.
 3. Size and material of the carrier pipe.

These items can not have an alternative and any application that is received that indicates options in any of the above items will not be processed.

- E. Once the application has been approved by the Engineering Representative, no variance from the approved plans, specifications, method of installation, construction, etc., will be considered or permitted without the payment to NCRR of additional fees for the re-processing of the application.

F. All plans and computations associated with the work under the agreement shall be prepared by, and bear the seal of, a Professional Engineer, If not so imprinted, the application will be given no further consideration. This requirement also applies to all data submitted by the Owner's contractor. Contractor's plans and computations that are not stamped will be returned and construction will not be permitted to proceed.

1.6.2 Specifications

A. Project specifications for all work on and affecting the railroad right-of-way, shall be included with the submission. All pertinent requirements of this document shall be included.

1.7 Notification to Proceed with Construction

A. After approval of the engineering plans and specifications and execution of the Occupancy Agreement, the Owner will be notified of the appropriate NCRR Operating Railroad office that must be contacted prior to start of construction. The Operating Railroad will provide inspection of the project and coordinate all other construction aspects of the project that relate to railroad operations (flagging, track work, protection of signal cables, etc.).

B. The Operating Railroad must be notified a minimum of fourteen (14) working days prior to desired start of construction.

2.0 GENERAL REQUIREMENTS

2.1 Use of a Casing Pipe

A. Casing pipes will be required for all pipeline crossings carrying liquid flammable or nonflammable substances under pressure. A casing pipe is also required for underground wire and cable crossings.

B. For flammable and nonflammable gas pipelines the casing pipe may be omitted provided the carrier pipe meets the requirements provided in the AREMA manual Chapter 1, Part 5, Section 5.2.3. The Engineering Representative may require use of a casing pipe at locations where increased risks from specific site conditions (track speed, traffic density, etc.) are present.

C. For non-pressure sewer or drainage crossings, where the installation can be made by open cut (see Section 5.1.2) the casing pipe may be omitted.

D. Pressure pipelines that do not cross under the track but are located within the NCRR right of way or closer than 45 feet to nearest point of any bridge, building or other important structure (as determined by the Engineering Representative), shall be encased.

E. The casing pipe shall be laid across the entire width of the right-of-way except where a greater length is required to comply with Section 4.3.1.F. of this specification, even though such extension is beyond the right-of-way. For non-pressure sewer or drainage crossings, where a casing is used for carrier pipe installation purposes only, the casing need only to extend from the boring pit to the receiving pit.

2.2 Location of Pipeline on the Right-of-Way

A. Pipelines laid longitudinally on NCRR's right-of-way shall be located as far as practicable from any tracks or other important structures and as close to the railroad property line as possible. Longitudinal pipelines must not be located in earth embankments or within ditches located on the right-of-way.

- B. Pipelines shall be located, where practicable, to cross tracks at approximate right angles to the track, but preferably at an angle to the centerline of track of not less than 45 degrees.
- C. Pipelines shall not be placed within a culvert, under railroad bridges, nor closer than 50 feet to any portion of any railroad bridge, building, or other important structure (as determined by the Engineering Representative), except in special cases, and then by special design, as approved by the Engineering Representative.
- D. Pipelines shall not be located within the limits of a turnout (switch) when crossing the track. The limits of the turnout extend from the point of the switch to the last long timber.
- E. Pipeline installations shall not be designed as an open cut installation where the pipeline is to be located within the limits of a grade crossing. If it is shown that no other method of installation is possible, the owner will be responsible for reimbursing NCR, and/or the Operating Railroad, for all costs associated with the removal and reconstruction of the grade crossing.
- F. Pipelines carrying liquefied petroleum gas shall, where practicable, cross the railroad where tracks are carried on embankment.
- G. Uncased gas pipelines must not be located within 25 feet of any track.

2.3 Depth of Installation

2.3.1 Pipelines conveying non-flammable substances

- A. Casing/carrier pipes placed under NCR track(s) shall be not less than 5 ½ feet from the base of rail to top of pipe at its closest point, except that under sidings or industry tracks this distance may be 4 ½ feet as approved by the Engineering Representative. On other portions of the right-of-way, where the pipe is not directly beneath any track, the minimum depth from ground surface to the top of pipe shall be 4 feet and from bottom of ditch to top of pipe the minimum depth shall not be less than 3 feet.
- B. Pipelines laid longitudinally on NCR's right-of-way, 50 feet or less from centerline track, shall be buried not less than 4 feet from ground surface to top of pipe. Where the pipeline is laid more than 50 feet from centerline of track, the minimum cover shall be at least 3 feet.

2.3.2 Pipelines conveying flammable substances

- A. Casing pipes under NCR track(s) shall be not less than 5 ½ feet from base of rail to top of pipe at its closest point, except that under sidings or industry tracks this distance may be 4 ½ feet as approved by the Engineering Representative. On other portions of the right-of-way, where the pipe is not directly beneath any track, the minimum depth from ground surface to top of pipe shall be 4 feet and from bottom of ditch to top of pipe the minimum depth shall not be less than 3 feet.
- B. Uncased gas pipelines, under NCR track(s), shall not be less than 10 feet from the base of rail to the top of the pipe at its closest point. At all other locations where crossing the right-of-way, the minimum ground cover must be 6 feet. Where it is not possible to obtain the above depths, use of a casing pipe will be required.
- C. Pipelines laid longitudinally on NCR's right-of-way, 50 feet or less from centerline track, shall be buried not less than 6 feet from ground surface to top of pipe. Where the pipeline is laid more than 50 feet from centerline of track, the minimum cover shall be at least 5 feet.

2.4 Pipelines within Limits of a Dedicated Highway

- A. Pipelines within the limits of a dedicated highway are subject to all the requirements of this specification and must be designed and installed in accordance with them.
- B. The limits of the dedicated highway (right-of-way) must be clearly shown on the plans.
- C. Construction can not begin until an Occupancy Agreement has been executed between NCRR and the Owner and proper notification has been given to Operating Railroad. (See Section 1.7)

2.5 Modification of Existing Facilities

- A. The contractor shall be responsible for determining the exact location of existing buried sewer lines, water lines and/or any other utilities that may conflict with the installation. The contractor shall endeavor to install the conduit without interrupting service and/or damaging other utilities. However, should interrupted service and/or damage to other utilities occur during the installation, the contractor shall be responsible for quickly restoring service and repairing damage at no cost to NCRR.
- B. Any replacement or modification of an existing carrier pipe and/or casing shall be considered as a new installation, subject to the requirements of this specification.

2.6 Abandoned Facilities

- A. The owner of all abandoned pipe crossings and other occupancies shall notify the Engineering Representative and the NCRR Property and Public Affairs Manager, in writing, of the intention to abandon.
- B. Abandoned pipelines shall be removed or completely filled with cement grout, compacted sand or other methods as approved by the Engineering Representative. Abandoned casing pipes shall be completely filled with cement grout, compacted sand or other methods as approved by the Engineering Representative.
- C. Abandoned manholes and other structures shall be removed to a minimum distance of 2 feet below finished grade and completely filled with cement grout or compacted sand.

2.7 Conflict of Specifications

- A. Where laws or orders of public authority prescribe a higher degree of protection than specified herein, then the higher degree so prescribed shall be deemed a part of this specification.

2.8 Insulation

- A. Pipelines and casings shall be suitably insulated from underground conduits carrying electric wires on NCRR property.

2.9 Corrosion Protection and Petroleum Leak Prevention

- A. Pipelines on NCRR property that carry petroleum products or hazardous liquids shall be designed in accordance with current federal, state and/or local regulations that mandate leak detection automatic shutoff, leak monitoring, and sacrificial anodes and/or exterior coatings to minimize corrosion and prevent petroleum releases.

3.0 SOIL INVESTIGATION

3.1 General

- A. Test borings or other soil investigations, approved by the Engineering Representative, shall be made to determine the nature of the underlying material for all pipe crossings 60 inches in diameter and larger under track(s). (See Section 1.4 relative to right of entry procedures)
- B. Test borings or other soil investigations, approved by the Engineering Representative, may be required when, in the judgment of the Engineering Representative, they are necessary to determine the adequacy of the design and construction of pipe crossings less than 60 inches in diameter and for other facilities located on the right-of-way.

3.2 Location

- A. Borings shall be made on each side of the track(s), on the centerline of the pipe crossing, and as close to the track(s) as practicable. (See Section 1.4 relative to procedures)
- B. Test boring logs shall be accompanied with a plan, drawn to scale, showing the location of the borings in relation to the track(s) and the proposed pipe.

3.3 Sampling

- A. Test borings shall be made in accordance with current ASTM Designation D 1586 except that sampling must be continuous from the ground surface to 5 feet below the proposed invert unless rock is encountered before this depth. Where rock is encountered, it is to be cored using a Series "M" Double Tube Core Barrel, with a diamond bit, capable of retrieving a rock core at least 1 5/8" in diameter. Individual core runs are not to exceed 5 feet in length.

3.4 Boring Logs

- A. Test boring logs shall comply with Plate VIII and clearly indicate all of the following:
 - 1. Boring number as shown on the required boring location plan.
 - 2. Ground elevation at each boring using same datum as the pipeline construction plans.
 - 3. Engineering description of soils or rock encountered.
 - 4. Depth and percent recovery of all soil samples.
 - 5. Depth from surface for each change in strata.
 - 6. Blows for each 6 inches of penetration for the standard penetration test described in ASTM D 1586. Blows for lesser penetrations should be recorded.
 - 7. Percent recovery and Rock Quality Designation (RQD) for all rock cores.
 - 8. Depth to ground water while sampling and when it has stabilized in the bore hole.
- B. The location of the carrier pipe and/or casing pipe shall be superimposed on the boring logs before submission to the Engineering Representative.
- C. All borings shall be sealed, for their full depth, with a 4-3-1 bentonite-cement-sand grout after accurate ground water readings have been taken and recorded.
- D. Soil samples taken from auger vanes or return wash water are not acceptable.

3.5 Additional Information

- A. When directed by the Engineering Representative, additional borings may be required for the purpose of taking undisturbed thin-wall piston samples or Dennison type samples for laboratory testing to determine the index and engineering properties of certain soil strata.

4.0 DESIGN REQUIREMENTS

4.1 Design Loads

4.1.1 General Requirements

- A. All pipes, manholes and other facilities shall be designed for the external and internal loads to which they will be subjected.
- B. To allow for placement of additional track(s) or shifting of the existing track(s), all proposed pipelines or structures shall be designed as if a railroad loading is directly above the facility.

4.1.2 Earth Load

- A. The dead load of the earth shall be considered as 120 pounds per cubic foot unless soil conditions warrant the use of a higher value.

4.1.3 Railroad Load (live load and impact)

- A. The railroad live load used shall be a Cooper E-80 loading. This loading consists of 80 kip axle loads spaced 5 feet on centers.
- B. An impact factor of 1.75 (multiply live load by the impact factor) shall be used for depth of cover up to 5 feet. Between 5 and 30 feet, the impact factor is reduced by 0.03 per foot of depth. Below a depth of 30 feet, the impact factor is one.
- C. The values shown in Table 1 shall be used for the vertical pressure on a buried structure for the various heights of cover.

Table I

Live loads, including impact, for various heights of cover for a Cooper E-80 loading.

Height of Cover	Load
feet	lb/sq ft
2	3800
3	3150
4	2850
5	2550
6	2250
7	1950
8	1700
9	1500
10	1300
12	1000

14	800
16	625
18	500
20	400
25	250
30	150

D. To determine the horizontal pressure caused by the railroad loading on a sheet pile wall or other structure adjacent to the track, the Boussinesq analysis shall be used. The load on the track shall be taken as a strip load with a width equal to the length of the ties, 8 1/2 feet. The vertical surcharge, q (psf), caused by each axle, shall be uniform and equal to the axle load divided by the tie length and the axle spacing, 5 feet. For the E-80 loading this results in;

$$q = 80,000 / (8.5 \times 5) = 1882 \text{ psf.}$$

The horizontal pressure due to the live load surcharge at any point on the wall or other structure is P_h and can be calculated by the following:

$$P_h = (2q/\pi)(\beta - \sin \beta(\cos 2\alpha)) \quad (\text{See PLATE IX})$$

E. The vertical and horizontal pressures given above shall be used unless an alternate design method is approved by the Engineering Representative. Proposals to use an alternate design method must include acceptable references and a statement explaining the justification for choosing the alternate method.

4.2 Design Assumptions

A. To design a casing pipe or an uncased carrier pipe for the external loads on NCR's right-of-way, the following design assumptions shall be used, unless site conditions indicate more conservative values are required:

B. Flexible Pipe (Steel, DIP, CMP, Tunnel Liner Plate)

1. Steel Pipe (Bored and jacked in place)

- Spangler's Iowa formula shall be used for design with:
 - a. Deflection lag factor $D_f = 1.5$
 - b. Modulus of soil reaction $E' = 1080 \text{ psi}$
 - c. Bedding constant $K_b = 0.096$
 - d. Soil loading constant $K_u = 0.13$
 - e. Allowable deflection of pipe 3% of pipe diameter

2. Ductile Iron Pipe (Open Cut)

- ANSI Specification A 21.50 shall be used for design with:
 - a. Pipe laying condition = Type 3 (see Sec. 5.1.2 for backfill requirements on RR R/W)
 - b. Earth load: ANSI A 51.50 prism method

3. Corrugated Steel Pipe & Corrugated Structural Steel Plate Pipe (Open Cut)

- AREMA Chapter 1, Part 4, Sections 4.9 & 4.10 shall be used for design with:
 - a. Soil stiffness factor: $K = 0.33$
 - b. Railroad impact as per Section 4.1.3.b. of this specification.

4. Tunnel Liner Plate (Tunneled)

- AREMA Chapter 1, Part 4, Section 4.16 shall be used for design with:
 - a. Soil stiffness factor: $K = 0.33$
 - b. Railroad impact as per Section 4.1.3.b. of this specification.

4.3 Casing Pipe

4.3.1 General Requirements

- A. Casing pipe shall be so constructed as to prevent leakage of any substance from the casing throughout its length, except at ends of casing where ends are left open, or through vent pipes when ends of casing are sealed. Casing shall be installed so as to prevent the formation of a waterway under the railroad, and with an even bearing throughout its length, and shall slope to one end (except for longitudinal occupancy).
- B. The casing pipe and joints shall be of steel and of leak proof construction when the pipeline is carrying liquid flammable products or highly volatile substances under pressure.
- C. The inside diameter of the casing pipe shall be such as to allow the carrier pipe to be removed subsequently without disturbing the casing or the roadbed. For steel pipe casings, the inside diameter of the casing pipe shall be at least 2 inches greater than the largest outside diameter of the carrier pipe joints or couplings, for carrier pipe less than 6 inches in diameter; and at least 4 inches greater for carrier pipe 6 inches and over in diameter.
- D. For flexible casing pipe, a maximum vertical deflection of the casing pipe of 3 percent of its diameter, plus ½ inch clearance shall be provided so that no loads from the roadbed, track, traffic or casing pipe itself are transmitted to the carrier pipe. When insulators are used on the carrier pipe, the inside diameter of the flexible casing pipe shall be at least 2 inches greater than the outside diameter of the carrier pipe for pipe less than 8 inches in diameter; at least 3 ¼ inches greater for pipe 8 inches to 16 inches, inclusive, in diameter and at least 4 ½ inches greater for pipe 18 inches and over in diameter.
- E. In no event shall the casing pipe diameter be larger than is necessary to permit the insertion of the carrier pipe.
- F. Casing pipe under railroad tracks and across NCRR's right-of-way shall extend the **greater** of the following distances, measured at right angle to centerline of track:
 - 1. Across the entire width of the NCRR right-of-way.
 - 2. 3 feet beyond the ditch line.
 - 3. 2 feet beyond the toe of slope.
 - 4. A minimum distance of 25 feet from each side of centerline of outside track when casing is sealed at both ends.
 - 5. A minimum distance of 45 feet from centerline of outside track when casing is open at both ends.
 - 6. Beyond the theoretical railroad embankment line. This line begins at a point, on existing grade, 14 feet horizontally from centerline track and extends downward on a 2 (horizontal) to 1 (vertical) slope. (See Plate III). The 14 feet is measured 19 inches below the base of rail.
- G. If additional tracks are constructed in the future, the casing shall be extended correspondingly at the Owner's expense.
- H. Like commodities may be located in the same encasement pipe. However, do not place flammable and non-flammable substances in the same encasement pipe. Neither shall encasement pipes contain combinations of drinking water and sewer pipes nor shall they contain wire lines with liquids or gasses in the same encasement pipe.

4.3.2 Steel Pipe

- A. Steel pipe may be installed by open cut, boring, jacking or other method approved by the Engineering Representative.
- B. Steel pipe shall have a specified minimum yield strength, SMYS, of at least 35,000 psi. The ASTM or API specification and grade for the pipe are to be shown on the Pipe Data Sheet (Plate I).
- C. Joints between the sections of pipe shall be fully welded around the complete circumference of the pipe.
- D. Steel casing pipe, with a minimum cover of 5½ ft., shall have a minimum wall thickness as shown in Table 2, unless computations indicate that a thicker wall is required.

Table 2

Pipe Diameter	Coated or Cathodically Protected	Uncoated and Unprotected
Nominal Pipe Size	Nominal Wall Thickness	Nominal Wall Thickness
inches	inches	inches
10 and under	0.188	0.188
12 & 14	0.188	0.250
16	0.219	0.281
18	0.250	0.312
20 & 22	0.281	0.344
24	0.312	0.375
26	0.344	0.406
28	0.375	0.438
30	0.406	0.469
32	0.438	0.500
34 & 36	0.469	0.532
38	0.500	0.562
40	0.531	0.594
42	0.562	0.625
44 & 46	0.594	0.657
48	0.625	0.688
50	0.656	0.719
52	0.688	0.750
54	0.719	0.781
56 & 58	0.750	0.812
60	0.781	0.844
62	0.812	0.875
64	0.844	0.906
66 & 68	0.875	0.938
70	0.906	0.969
72	0.938	1.000

- E. Coated steel pipe that is bored or jacked into place shall conform to the wall thickness requirements for uncoated steel pipe since the coating may be damaged during installation.
- F. Smooth wall steel pipes with a nominal diameter over 72 inches will not be permitted.

4.3.3 Ductile Iron Pipe

- A. Ductile iron pipe may be used only when placed by the open cut method. Jacking or boring through the railroad embankment is not permitted due to the bell and spigot joints.
- B. Ductile iron pipe shall conform to the requirements of ANSI A21.51/AWWA C-151. Class 56 pipe shall be used unless computations, in accordance with Sections 4.1 and 4.2, are provided.
- C. Table 3 is based on the design assumptions given in Section 4.2. b. (2) with a minimum cover of 5 ½ ft. This table is provided for information only.

Table 3

Pipe Diameter	Thickness Class		Pressure Class	
	Wall Thickness	Class	Wall Thickness	Class
Inches	Inches		Inches	
3	0.25	51	0.25	350
4	0.26	51	0.25	350
6	0.25	50	0.25	350
8	0.27	50	---	---
10	0.32	51	---	---
12	0.34	51	---	---
14	0.39	52	---	---
16	0.40	52	---	---
18	0.44	53	---	---
20	0.45	53	---	---
24	0.53	55	---	---
30	0.63	56	---	---
36	0.73	56	---	---
42	0.83	56	---	---
48	0.93	56	---	---
54	1.05	56	---	---

- D. The pipe shall have mechanical or restrained type joints.

4.3.4 Corrugated Steel Pipe and Corrugated Structural Steel Plate Pipe

- A. Corrugated steel pipe and corrugated structural steel plate pipe may be used for a casing only when placed by the open cut method. Jacking or boring through the railroad embankment is not permitted.
- B. Corrugated steel pipe and corrugated structural steel plate pipe may be used for a casing provided the pressure in the carrier pipe is less than 100 psi.
- C. Pipe shall be bituminous coated and shall conform to the current American Railway Engineering and Maintenance of Way Association Specifications Chapter 1, Part 4.

D. Corrugated steel pipe shall have a minimum sheet thickness as shown in Table 4. Corrugated structural steel plate pipe shall have a minimum plate thickness of 8 gage, 0.168 in. If computations indicate that a greater thickness is required, the thicker sheet or plate shall be used.

Table 4

Pipe Diameter	Sheet Thickness	
	Gage	Inches
12 to 30	14	0.079
36	12	0.109
42 to 54	10	0.138
60 to 120	8	0.168

4.3.5 Steel Tunnel Liner Plates

- A. Liner plates shall be installed by the tunneling method as detailed in Section 5.1.5 of this specification.
- B. Tunnel liner plates shall be galvanized and bituminous coated and shall conform to current American Railway engineering and Maintenance of Way Association Specification Chapter 1, Part 4, Section 4.16. If the tunnel liner plates are used only to maintain a tunneled opening until the carrier pipe is installed, and the annular space between the carrier pipe and the tunnel liner is completely filled with cement grout within a reasonably short time after completion of the tunnel, then the tunnel liner plates need not be galvanized and coated.
- C. Tunnel liner plates are to be a minimum of 12 gage and shall be fabricated from structural quality, hot-rolled, carbon-steel sheets or plates conforming to ASTM Specification A 569.
- D. The following liner plate information must be shown on the Pipe Data Sheet (Plate D):
 - 1. Number of flanges (2 or 4)
 - 2. Width of plate
 - 3. Type of plate (smooth or corrugated)

4.3.6 Concrete Encasement

- A. At locations where the installation is by open cut and a casing pipe is required, but can not be installed due to elbows or other obstructions, concrete encasement may be used when approved by the Engineering Representative.
- B. The concrete encasement must provide a minimum cover of 6 inches of concrete around the pipe. A 6 x 6 - W 2.9 x W 2.9 welded wire fabric shall be placed in the concrete on all sides.

4.4 Carrier Pipe

4.4.1 General Requirements

- A. The pipe shall be laid with sufficient slack so that it is not in tension.
- B. Steel pipe shall not be used to convey sewage, storm water or other liquids which could cause corrosion.
- C. Carrier pipes located on NCR's right-of-way or under tracks over which the Operating Railroad operates, shall be manufactured in accordance with the following specifications:

1. Steel Pipe - The ASTM or API specification and grade for the pipe is to be shown on the Pipe Data Sheet. The specified minimum yield strength is to be at least 35,000 psi. For flammable substances see Sections 4.4.2 and 4.4.3 for additional requirements.
 2. Ductile Iron Pipe - ANSI A21.51/AWWA C151
 3. Corrugated Metal Pipe - AREMA Chapter 1, Part 4
- D. Carrier pipes installed within a casing pipe shall be designed for the internal pressure to which it will be subjected.
- E. Gravity flow carrier pipes, installed without a casing pipe, shall meet the requirements, of the particular pipe material, as given in Section 4.3 of this specification.
- F. Design computations, stamped by a P.E., must be submitted for all uncased pressure pipelines installed on NCR's right-of-way. The pipe must be designed for the internal and external loads (see Section 4.1) to which it may be subjected. The design assumptions given in Section 4.2 shall apply.
- G. Reinforced concrete pipe will not be allowed for pipeline crossings except as a carrier pipe when the pipeline is operated under gravity flow and a casing pipe is provided.

4.4.2 Pipelines Carrying Flammable Substances

- A. Pipelines carrying oil, liquefied petroleum gas and other flammable products shall be of steel and conform to the requirements of the current ANSI B 31.4 Liquid Transportation Systems for hydrocarbons, Liquid Petroleum Gas, Anhydrous Ammonia, and Alcohols, and other applicable ANSI codes, except that the maximum allowable stresses for design of steel pipe shall not exceed the following percentages of the specified minimum yield strength (multiplied by the longitudinal joint factor) of the pipe as defined in the above codes:
1. The following percentages apply to hoop stress in steel pipe within a casing under railroad tracks, across railroad right-of-way and longitudinally on railroad right-of-way:
 - a. Seventy-two percent on oil pipelines.
 - b. Fifty percent for pipelines carrying condensate, natural gasoline, natural gas liquids, liquefied petroleum gas, and other liquid petroleum products.
 - c. Sixty percent for installations on gas pipelines.
 2. The following percentages apply to hoop stress in steel pipe laid longitudinally on railroad right-of-way without a casing:
 - a. Sixty percent for oil pipelines.
 - b. Forty percent for pipelines carrying condensate, natural gasoline, natural gas liquids, liquefied petroleum gas, and other liquid petroleum products.
 - c. For gas pipelines see Section 4.4.3.B.
- B. Computations, based on the above requirements and stamped by a P.E., shall be submitted with the application for occupancy.

4.4.3 Uncased Pipelines Carrying Gas

- A. Pipelines carrying flammable and nonflammable gas products shall be steel and shall conform to the requirements of the current ANSI B 31.8 Gas Transmission and Distribution Piping Systems, and other applicable ANSI codes.
- B. The minimum wall thickness for uncased carrier pipe shall be in accordance with the values provided in AREMA, Chapter 1, Part 5, Section 5.2, Table 1-5-3.

- C. A durable coating, which will resist abrasion (fusion bonded epoxy or other suitable material), shall be used to protect the uncased pipeline when the boring method of installation is used.
- D. If the Engineering Representative determines there is the potential for damage to the uncased pipeline (foreign material in the subgrade, third party damage, etc.), special protection of the pipeline will be required. Special protection may include the use of a protection slab over the pipeline, increased depth of bury or other means.

4.5 Casing Pipe End Seals

- A. Casings for carrier pipes of flammable and hazardous substances shall be suitably sealed to the outside of the carrier pipe. Details of the end seals shall be shown on the plans.
- B. Casings for carrier pipes of nonflammable substances shall have both ends of the casing blocked up in such a way as to prevent the entrance of foreign material, but allowing leakage to pass in the event of a carrier break.
- C. The ends of a casing pipe may be left open when the ends are at or above ground surface and above high water level, provided drainage is afforded in such a manner that leakage will be conducted away from railroad tracks and structures.

4.6 Vents

- A. Sealed casings for flammable substances shall be properly vented. Vent pipes shall be of sufficient diameter, but in no case less than two inches in diameter, and shall be attached near each end of the casing and project through the ground surface at right-of-way lines or not less than 45 feet, measured at right angles from centerline of nearest track.
- B. Vent pipes shall extend not less than 4 feet above the ground surface. Top of vent pipe shall have a down-turned elbow, properly screened, or a relief valve. Vents in locations subject to high water shall be extended above the maximum elevation of high water and shall be supported and protected in a manner approved by the Engineering Representative.
- C. Vent pipes shall be at least 4 feet, vertically, from aerial electric wires or greater if required by National Electrical Safety Code (ANSI C2).
- D. When the pipeline is in a public highway, street-type vents shall be installed.

4.7 Signs

- A. All pipelines (except those in streets where it would not be practical to do so) shall be prominently marked at right-of-way lines (on both sides of track for crossings) by durable, weatherproof signs located over the centerline of the pipe. Signs shall show the following:
 - 1. Name and address of owner
 - 2. Contents of pipe
 - 3. Pressure in pipe and/or voltage of conduit.
 - 4. Pipe depth below grade at point of a sign
 - 5. Emergency telephone number in event of pipe rupture
- B. For pipelines running longitudinally on NCRR property, signs shall be placed over the pipe (or offset and appropriately marked) at all changes in direction of the pipeline. Such signs should also be located so that when standing at one sign the next adjacent marker in either direction is visible. In no event shall they be placed more than 500 feet apart unless otherwise specified by the Engineering Representative.

C. The Owner must maintain all signs on NCR's right-of-way as long as the occupational agreement is in effect.

4.8 Warning Tape

- A. All pressure pipelines and underground conduit installed by the trench method, without a casing, shall have a warning tape placed directly above the pipeline, 2 feet below the ground surface.
- B. Wire conduit marking tape shall be yellow in color and be marked "CAUTION – BURIED ELECTRICAL CABLE." Text shall be black in color.

4.9 Shut-off Valves

- A. Accessible emergency shut-off valves shall be installed within effective distances each side of the railroad at locations selected by the Engineering Representative where hazard to life and property must be guarded against. No additional valves will be required where pipelines are provided with automatic control stations and within distances approved by the Engineering Representative.

4.10 Cathodic Protection

- A. Cathodic protection shall be applied to all pipelines carrying flammable substances on NCR's right-of-way.
- B. For crossings and at other locations where the pipeline must be placed within a casing, the casing is to have cathodic protection or the wall thickness is to be increased to the requirements of Section 4.3.2 Table 2.
- C. Uncased gas carrier pipes must be coated and cathodically protected to industry standards and test sites, for monitoring the pipeline, provided within 50 feet of the crossing.
- D. Where casing and/or carrier pipes are cathodically protected by other than anodes, the Engineering Representative shall be notified and a suitable test made to ensure that other railroad structures and facilities are adequately protected from the cathodic current in accordance with the recommendation of current Reports of Correlating Committee on Cathodic Protection, published by the National Association of Corrosion Engineers.
- F. Where sacrificial anodes are used the locations shall be marked with durable signs.

4.11 Manholes

- A. Manholes shall not be located on NCR property where possible. At locations where this is not practical, including longitudinal occupancies, manholes shall be precast concrete sections conforming to ASTM Designation C 478, "Specification for Precast Concrete Manhole Sections".
- B. The top of manholes located on NCR property shall be flush with top of ground.
- C. The distance from centerline of adjacent track to centerline of proposed manhole shall be shown on the plans.

4.12 Box Culverts

- A. Reinforced concrete box culverts shall conform to the requirements of AREMA Chapter 8, Parts 13 and 16.

4.13 Drainage

- A. Occupancies shall be designed, and their construction shall be accomplished, so that adequate and uninterrupted drainage of NCRR's right-of-way is maintained.
- B. All pipes, ditches and other structures carrying surface drainage on NCRR property and/or under NCRR track(s) shall be designed to carry the run-off from a one hundred (100) year storm. Computations indicating this design, prepared by a Professional Engineer, and suitable topographic plans, outlining the total drainage area, shall be submitted for NCRR's approval. All drainage applications are also subject to review and approval of the Operating Railroad.
- C. If the drainage is to discharge into an existing drainage channel on NCRR's right-of-way and/or through a drainage structure under NCRR's track(s), the computations must include the hydraulic analysis of any existing ditch and/or structure.
- D. When calculating the capacity of existing or proposed drainage structures, under NCRR's track(s), the headwater, at the structure shall not be greater than 1.5.
- E. Pipe(s) used to carry surface drainage on NCRR's right-of-way shall have a minimum diameter of 36 inches.
- F. Detention ponds must not be placed on any part of NCRR's right-of-way. Also, the railroad embankment must not be used as any part of a detention pond structure.
- G. Formal approval of the proposed design, by the appropriate governmental agency having jurisdiction, shall be submitted with the drainage computations.

4.14 Pipelines on Bridges

- A. Pipelines of any type shall not be installed on any bridge carrying NCRR tracks.
- B. New overhead pipe bridges shall not be constructed over NCRR's right-of-way where underground installation of the pipeline is possible. Where the Applicant can show that no practicable alternative is available, this type of structure will be permitted provided the following conditions are met:
 - 1. The vertical clearance, distance from top of rail to bottom of structure, is shown and is a minimum of 23 feet, measured at a point 6 feet horizontally from centerline track.
 - 2. The support bents for the overhead structure are located off NCRR's right-of-way or a minimum clear distance of 18 feet from centerline track, whichever distance is greater.
 - 3. Support bents within 25 feet of centerline track have pier protection in accordance with AREMA, Chapter 8, Part 2, Section 2.1.5.
 - 4. Complete structural plans and design computations for the structure and foundations, stamped by a Professional Engineer, are submitted with the application.
 - (5) A fence (with barbed wire) or other measures are provided which will prevent access to the bridge by unauthorized personnel or vandals.
- C. Pipelines carrying flammable substances or non-flammable substances, which by their nature might cause damage if escaping on or near railroad facilities or personnel, shall not be installed on bridges over NCRR tracks. In special cases when it can be demonstrated to the Engineering Representative's satisfaction that such an installation is necessary and that no practicable alternative is available, the Engineering Representative may permit the installation but only by special design approved by him.

D. When permitted, pipelines on bridges over NCRR tracks shall be so located as to minimize the possibility of damage from vehicles, railroad equipment, vandalism and other external causes. They shall be encased in a casing pipe as directed by the Engineering Representative (See Plate VII). Applications which involve attachments to public bridges crossing NCRR property must include evidence of approval by the governing agency.

5.0 CONSTRUCTION REQUIREMENTS

5.1 Method of Installation

5.1.1 General Requirements

- A. Bored, jacked or tunneled installations shall have a bore hole essentially the same as the outside diameter of the pipe plus the thickness of the protective coating.
- B. The use of water or other liquids to facilitate casing emplacement and spoil removal is prohibited.
- C. If during installation an obstruction is encountered which prevents installation of the pipe in accordance with this specification, the pipe shall be abandoned in place and immediately filled with grout. A new installation procedure and revised plans must be submitted to, and approved by, the Engineering Representative before work can resume.

5.1.2 Open Cut

- A. The Owner must request open cut approval when making application for occupancy.
- B. Installations beneath the track by open trench methods will be permitted only with the approval of the Operating Railroad.
- C. Installations by open cut will not be permitted under mainline tracks, tracks carrying heavy tonnage or tracks carrying passenger trains. Also, open cut shall not be used within the limits of a highway/railroad grade crossing or its approaches, 25 feet either side of traveled way, where possible. The open cut installation method is limited to fills less than or equal to 10 feet as measured from the pipe flow line to the base of rail.
- D. At locations where open cut is permitted, the trench is to be backfilled with crushed stone with a top size of the aggregate to be a maximum of 2 inches and to have no more than 5% passing the number 200 sieve. The gradation of the material is to be such that a dense stable mass is produced.
- E. The backfill material shall be placed in loose 6 inch lifts and compacted to at least 95% of its maximum density with a moisture content that is no more than 1 % greater than or 2% less than the optimum moisture as determined in accordance with current ASTM Designation D 1557 (Modified Proctor). When the backfill material is within 3 feet of the subgrade elevation (the interface of the ballast and the subsoil) a compaction of at least 98% will be required. Compaction test results confirming compliance must be provided to the Operating Railroad and the Engineering Representative by the Owner.
- F. All backfilled pipes laid either perpendicular or parallel to the tracks must be designed so that the backfill material will be positively drained. This may require the placement of lateral drains on pipes laid longitudinally to the track and the installation of stub perforated pipes at the edge of the slopes.
- G. Unless otherwise agreed upon, all work involving rail, ties and other track material will be performed by Operating Railroad employees at the sole expense of the Owner.

5.1.3 Bore and Jack (Steel Pipe)

- A. This method consists of pushing the pipe into the earth with a boring auger rotating within the pipe to remove the spoil.
- B. The boring operation shall be progressed on a 24-hour basis without stoppage (except for adding lengths of pipe) until the leading edge of the pipe has reached the receiving pit.
- C. The front of the pipe shall be provided with mechanical arrangements or devices that will positively prevent the auger from leading the pipe so that no unsupported excavation is ahead of the pipe.
- D. The auger and cutting head arrangement shall be removable from within the pipe in the event an obstruction is encountered. If the obstruction cannot be removed without excavation in advance of the pipe, procedures as outlined in Section 5.1.1 C. must be implemented immediately.
- E. The over-cut by the cutting head shall not exceed the outside diameter of the pipe by more than ½ inch. If voids should develop or if the bored hole diameter is greater than the outside diameter of the pipe (plus coating) by more than approximately 1 inch, grouting (see Section 5.2) or other methods approved by the Engineering Representative, shall be employed to fill such voids.
- F. The face of the cutting head shall be arranged to provide a reasonable obstruction to the free flow of soft or poor material.
- G. Construction shall be carried on in such a manner that settlement of the ground surface above the pipe line shall be held to an absolute minimum.
- H. Plans and description of the arrangement to be used shall be submitted to the Engineering Representative for approval and no work shall proceed until such approval is obtained.
- I. Any method that employs simultaneous boring and jacking for pipes over 8 inches in diameter that does not have the above approved arrangement **will not be permitted**. For pipe 8 inches and less in diameter, augering or boring without this arrangement may be considered for use only as approved by the Engineering Representative.

5.1.4 Jacking (Steel Pipe)

- A. This method consists of pushing sections of pipe into position with jacks placed against a backstop and excavation performed by hand from within the jacking shield at the head of the pipe. Ordinarily 36 inch pipe is the least size that should be used, since it is not practical to work within smaller diameter pipes.
- B. Jacking shall be in accordance with the current AREMA Specifications, Chapter 1, Part 4, Section 4.13 "Earth Boring and Jacking Culvert Pipe Through Fills". This operation shall be conducted without hand-mining ahead of the pipe and without the use of any type of boring, auguring, or drilling equipment.
- C. Bracing and backstops shall be so designed and jacks of sufficient rating used so that the jacking can be progressed on a 24-hour basis without stoppage (except for adding lengths of pipe) until the leading edge of the pipe has reached the receiving pit.
- D. Immediately upon completion of jacking operations, the installation shall be pressure grouted as per Section 5.2 of this specification.

5.1.5 Tunneling (Tunnel liner plate)

- A. This method consists of placing rings of liner plate within the tail section of a tunneling shield or tunneling machine. A tunneling shield shall be used for all liner plate installations unless otherwise approved by the Engineering Representative.
- B. The shield shall be of steel construction, designed to support a railroad track loading as specified in Section 4.1.3 of this specification, in addition to the other loadings imposed. The advancing face shall be provided with a hood, extending no less than 20 inches beyond the face and extending around no less than the upper 240 degrees of the total circumference. It shall be of sufficient length to permit the installation of at least one complete ring of liner plates within the shield before it is advanced for the installation of the next ring of liner plates. The shield shall conform to and not exceed the outside dimensions of the liner plate tunnel being placed by more than 1 inch at any point on the periphery unless otherwise approved by the Engineering Representative.
- C. The shield shall be adequately braced and provided with necessary appurtenances for completely bulkheading the face with horizontal breastboards, and arranged so that the excavation can be benched as may be necessary. Excavation shall not be advanced beyond the edge of the hood, except in rock.
- D. Manufacturer's shop detail plans and manufacturer's computations showing the ability of the tunnel liner plates to resist the jacking stresses shall be submitted to the Engineering Representative for approval.
- E. Unless otherwise approved by the Engineering Representative, the tunneling shall be conducted continuously, on a 24-hour basis, until the tunnel liner extends at least beyond the theoretical railroad embankment line (See Plate III).
- F. At any interruption of the tunneling operation, the heading shall be completely bulkheaded.
- G. The liner plates shall have tapped grout holes for no smaller than 1½ inch pipe, spaced at approximately 3 feet around the circumference of the tunnel liner and 4 feet longitudinally.
- H. Grouting behind the liner plates shall be in accordance with Section 5.2 of this specification.

5.1.6 Directional Boring / Horizontal Directional Drilling (Steel Pipe)

Method "A"

- A. This method consists of setting up specialized drilling equipment on existing grade (launching and receiving pits are not required) and boring a small diameter pilot hole on the desired vertical and horizontal alignment, using a mechanical cutting head with a high pressure fluid (bentonite slurry) to remove the cuttings. The drill string is advanced with the bentonite slurry pumped through the drill string to the cutting head and then forced back along the outside of the drill string carrying the cuttings back to the surface for removal. When the cutting head reaches the far side of the crossing, it is removed and a reamer (with a diameter greater than the cutting head) is attached to the lead end of the drill string. The pipeline is attached to the reamer and the pilot hole is then back reamed while the pipeline is pulled into place.
- B. This method is used to place pipelines under rivers, wetlands and other obstructions which would be difficult to cross by conventional methods. The length of the bore is generally several hundred feet in length, with installations over a thousand feet possible.

- C. Consideration will be given where the depth of cover is greater than 10 feet below the base of rail, or the bore is in rock. Factors considered will be track usage, pipe size, contents of pipeline, soil conditions, etc.
- D. The following preliminary information must be submitted with the request for consideration of this type of installation:
 1. A site plan of the area.
 2. A plan view and profile of the crossing.
 3. A Pipe Data Sheet.
 4. Several soil borings along the proposed pipeline route.
 5. A construction procedure, including a general description of equipment to be used.

If the Engineering Representative determines this method of installation is acceptable, final design plans and specifications are to be prepared and submitted for approval.

- E. The project specifications must require the contractor to submit, to the Engineering Representative for approval, a complete construction procedure of the proposed boring operation. Included with the submission shall be the manufacture's catalog information describing the type of equipment to be used.

Method "B"

- A. This method is used to place small diameter conduit for electric lines and other utilities. This method consists of using hydraulic jacking equipment to push a solid steel rod under the railroad from a launching pit to a receiving pit. At the receiving pit, a cone shaped "expander" is attached to the end of the rod and the conduit (casing pipe) is attached to the expander. The rod, expander and conduit are then pulled back from the launching pit until the full length of the conduit is in place.
- B. This method may be used to place steel conduit (casing pipe), up to and including 6 inches in diameter, under the railroad.
- C. The project specifications must require the contractor to submit, to the Engineering Representative for approval, a complete construction procedure of the proposed boring operation. Included with the submission shall be the manufacture's catalog information describing the type of equipment to be used.

5.2 Grouting

- A. For jacked and tunneled installations a uniform mixture of 1:6 (cement:sand) cement grout shall be placed under pressure through the grout holes to fill any voids which exist, between the pipe or liner plate and the undisturbed earth.
- B. Grouting shall start at the lowest hole in each grout panel and proceed upwards simultaneously on both sides of the pipe.
- C. A threaded plug shall be installed in each grout hole as the grouting is completed at that hole.
- D. When grouting tunnel liner plates, grouting shall be kept as close to the heading as possible, using grout stops behind the liner plates if necessary. Grouting shall proceed as directed by the Engineering Representative, but in no event shall more than 6 lineal feet of tunnel be progressed beyond the grouting.

5.3 Soil Stabilization

- A. Pressure grouting of the soils or freezing of the soils before jacking, boring, or tunneling may be required at the direction of the Engineering Representative to stabilize the soils, control water, prevent loss of material

and prevent settlement or displacement of embankment. Grout shall be cement, chemical or other special injection material selected to accomplish the necessary stabilization.

- B. The materials to be used and the method of injection shall be prepared by a Registered Professional Soils Engineer, or by an experienced and qualified company specializing in this work and submitted for approval to the Engineering Representative before the start of work. Proof of experience and competency shall accompany the submission.

5.4 Dewatering

- A. When water is known or expected to be encountered, pumps of sufficient capacity to handle the flow shall be maintained at the site, provided the contractor has received approval from the Engineering Representative to operate them. Pumps in operation shall be constantly attended on a 24-hour basis until, in the sole judgment of the Engineering Representative, the operation can be safely halted. When dewatering, close observation shall be maintained to detect any settlement or displacement of railroad embankment, tracks, and facilities.

5.5 Safety Requirements

- A. All operations shall be conducted so as not to interfere with, interrupt, or endanger the operation of trains or damage, destroy, or endanger the integrity of railroad facilities. All work on or near NCCR property shall be conducted in accordance with the Operating Railroad's safety rules and regulations. The contractor shall secure and comply with the Operating Railroad's safety rules and shall give written acknowledgment to the Operating Railroad that they have been received, read, and understood by the contractor and its employees. Operations will be subject to inspection by the Operating Railroad and/or the Engineering Representative at any and all times.
- B. All cranes, lifts, or other equipment that will be operated in the vicinity of the railroad's electrification and power transmission facilities shall be electrically grounded as directed by the Operating Railroad.
- C. At all times when the work is being progressed, a field supervisor for the work with no less than twelve (12) months experience in the operation of the equipment being used shall be present. If boring equipment or similar machines are being used, the machine operator also shall have no less than twelve (12) months experience in the operation of the equipment being used.
- D. Whenever equipment or personnel are working closer than 15 feet from the centerline of an adjacent track, that track shall be considered as being obstructed. Insofar as possible, all operations shall be conducted no less than this distance. Operations closer than 15 feet from the centerline of a track shall be conducted only with the permission of, and as directed by, a duly qualified employee of the Operating Railroad present at the site of the work.
- E. Crossing of tracks at grade by equipment and personnel is prohibited except by prior arrangement with the Engineering Representative, and as directed by a qualified employee of the Operating Railroad.

5.6 Blasting

- A. Blasting will not be permitted.

5.7 Temporary Track Supports

- A. When the jacking, boring or tunneling method of installation is used, and depending upon the size and location of the crossing, the need for temporary track supports will be determined by the Engineering Representative.

- B. Details of the temporary track supports shall conform to the specifications of the Operating Railroad.
- C. The Owner's contractor shall supply the track supports with installation and removal performed by Operating Railroad employees.
- D. The Owner shall reimburse the Operating Railroad for all costs associated with the installation and removal of the track supports.

5.8 Protection of Drainage Facilities

- A. If, in the course of construction, it may be necessary to block a ditch, pipe or other drainage facility, temporary pipes, ditches or other drainage facilities shall be installed to maintain adequate drainage, as approved by the Engineering Representative and the Operating Railroad. Upon completion of the work, the temporary facilities shall be removed and the permanent facilities restored.
- B. Soil erosion methods shall be used to protect railroad ditches and other drainage facilities during construction on and adjacent to NCR's right-of-way.

5.9 Support of Excavation Adjacent to Track

5.9.1 Launching and Receiving Pits

- A. The location and dimensions of all pits or excavations shall be shown on the plans. The distance from centerline of adjacent track to face of pit or excavation shall be clearly labeled. Also, the elevation of the bottom of the pit or excavation must be shown on the profile.
- B. The face of all pits shall be located a minimum of 25 feet from centerline of adjacent track, measured at right angles to track, unless otherwise approved by the Engineering Representative and the Operating Railroad.
- C. If the bottom of the pit excavation intersects the theoretical railroad embankment line (See Plate III) interlocking steel sheet piling, driven prior to excavation, must be used to protect the track stability. The use of trench boxes or similar devices is not acceptable in this area.
- D. Design plans and computations for the pits, stamped by a Professional Engineer, must be submitted by the Owner at time of application or by the contractor prior to start of construction. If the pit design is to be submitted by the contractor, the project specifications must require the contractor to obtain NCR's approval prior to beginning any work on or which may affect NCR property.
- E. The sheeting shall be designed to support all lateral forces caused by the earth, railroad and other surcharge loads. See Section 4.1.3 for railroad loading.
- F. After construction and backfilling, all sheet piling within 10 feet of centerline track must be cut off 18 inches below final grade and left in place.
- G. All excavated areas are to be illuminated (flashing warning lights not permitted), fenced and otherwise protected as directed by the Operating Railroad.

5.9.2 Parallel Trenching and Other Excavation

- A. When excavation for a pipeline or other structure will be within the theoretical railroad embankment line (See Plate V) of an adjacent track, interlocking steel sheet piling will be required to protect the track.

B. The design and construction requirements for this construction shall be in accordance with the requirements of Section 5.9.1.

5.10 Inspection and Testing

A. For pipelines carrying flammable or hazardous materials, ANSI Codes, current at time of constructing the pipeline, shall govern the inspection and testing of the facility on NCRR property, except as follows:

- (1) One-hundred percent of all field welds shall be inspected by radiographic examinations, and such field welds shall be inspected for 100 percent of the circumference.
- (2) The proof testing of the strength of carrier pipe shall be in accordance with ANSI requirements.

5.11 Reimbursement of Costs

A. All NCRR, Operating Railroad and Engineering Representative costs associated with the pipe installation (application review, inspection, flagging, track work, protection of signal cables, etc.) shall be reimbursed by the Owner of the facility. Reimbursement by the contractor is not acceptable.

PLATE I

PIPE DATA SHEET
(For crossings and longitudinal occupancy)

	PIPE DATA	
	CARRIER PIPE	CASING PIPE
CONTENTS TO BE HANDLED		
NORMAL OPERATING PRESSURE		
NOMINAL SIZE OF PIPE		
OUTSIDE DIAMETER		
INSIDE DIAMETER		
WALL THICKNESS		
WEIGHT PER FOOT		
MATERIAL		
PROCESS OF MANUFACTURE		
SPECIFICATION		
GRADE OR CLASS		
TEST PRESSURE		
TYPE OF JOINT		
TYPE OF COATING		
DETAILS OF CATHODIC PROTECTION		
DETAILS OF SEALS OR PROTECTION AT ENDS OF CASING		
METHOD OF INSTALLATION		
CHARACTER OF SUBSURFACE MATERIAL AT THE CROSSING LOCATION		
APPROXIMATE GROUND WATER LEVEL		
SOURCE OF INFORMATION ON SUBSURFACE CONDITIONS (BORINGS, TEST PITS OR OTHER)		
TOTAL LENGTH WITHIN RIGHT OF WAY		

NOTE: Any soil investigation made on railroad property or adjacent to tracks shall be carried on under the supervision of the Engineering Representative and/or the Operating Railroad. (See Section 1.4)

PLATE II

INFORMATION TO BE SHOWN ON PLAN VIEW OF DRAWINGS
WHEN FACILITY IS A CROSSING

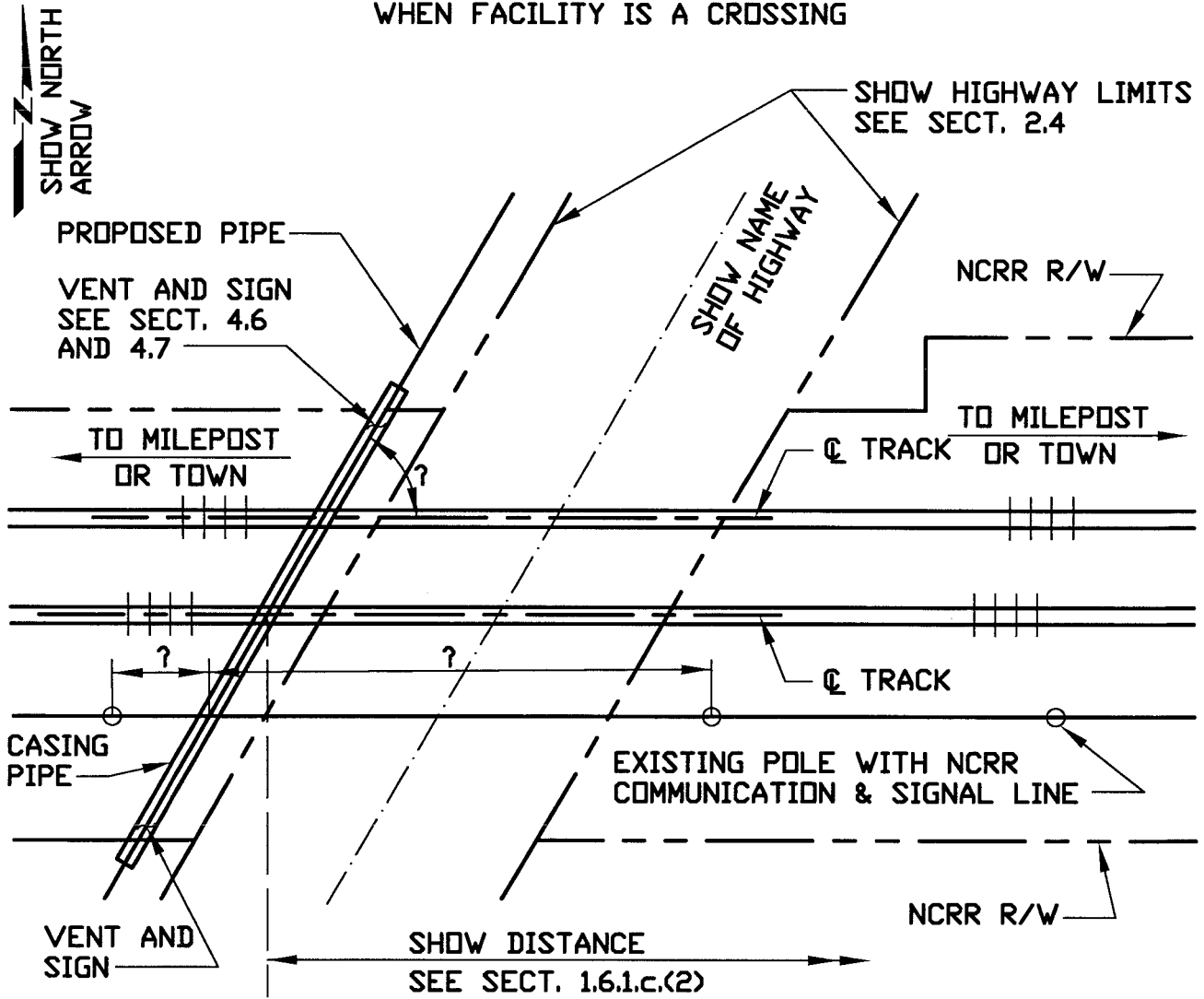

PLAN

SCALE OF DRAWING TO BE SHOWN

NOTES:

IF THE PROPOSED PIPE LINE IS WITHIN HIGHWAY LIMITS, THE SAME INFORMATION IS REQUIRED AS SHOWN ON THIS PLATE.

IF THE PROPOSED PIPE IS TO SERVE A NEW DEVELOPMENT, A MAP SHOWING THE AREA IN RELATION TO ESTABLISHED AREAS AND ROADS IS TO BE SENT WITH THE REQUEST.

PLATE III

PIPELINE CROSSING

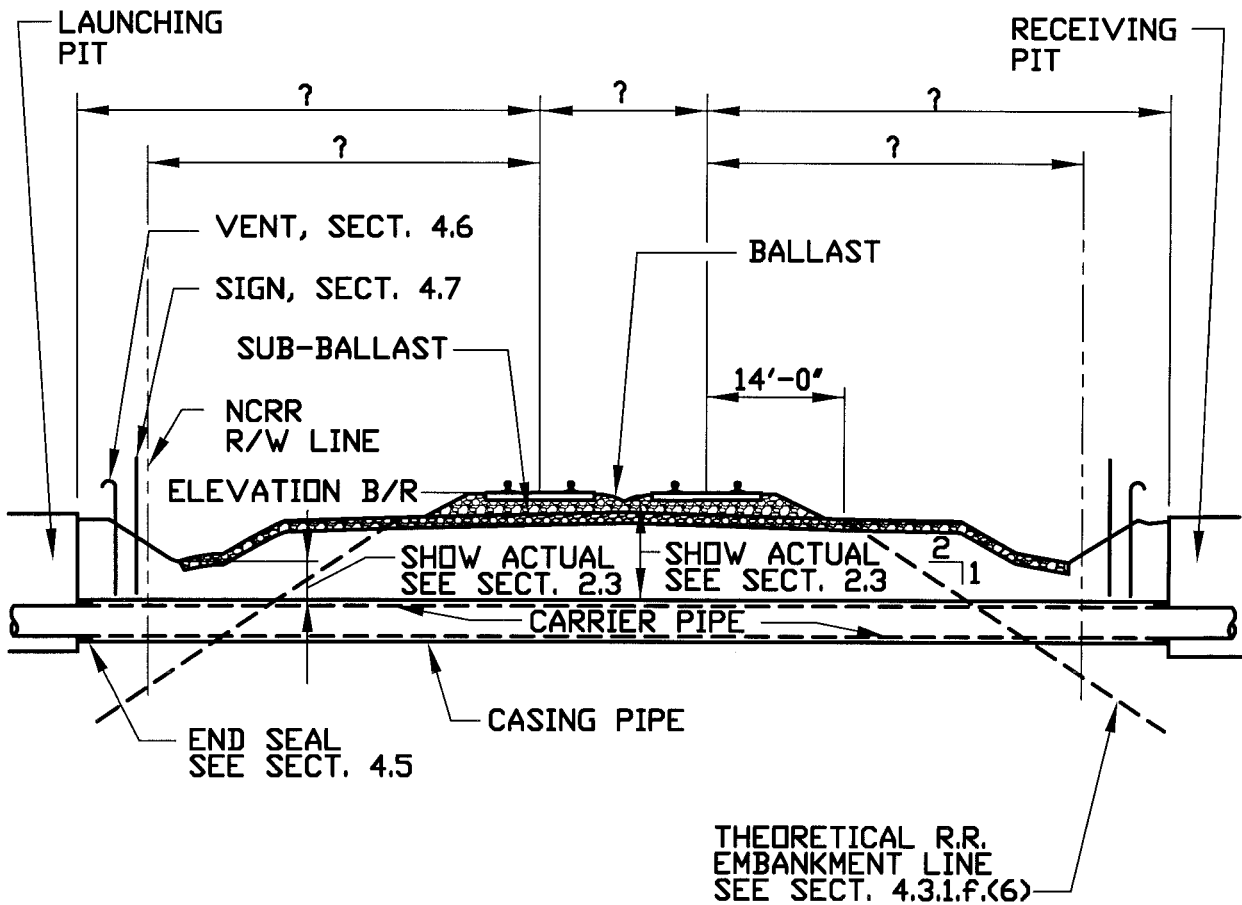

PROFILE

SCALE OF DRAWING TO BE SHOWN

PLATE IV

LONGITUDINAL OCCUPANCY

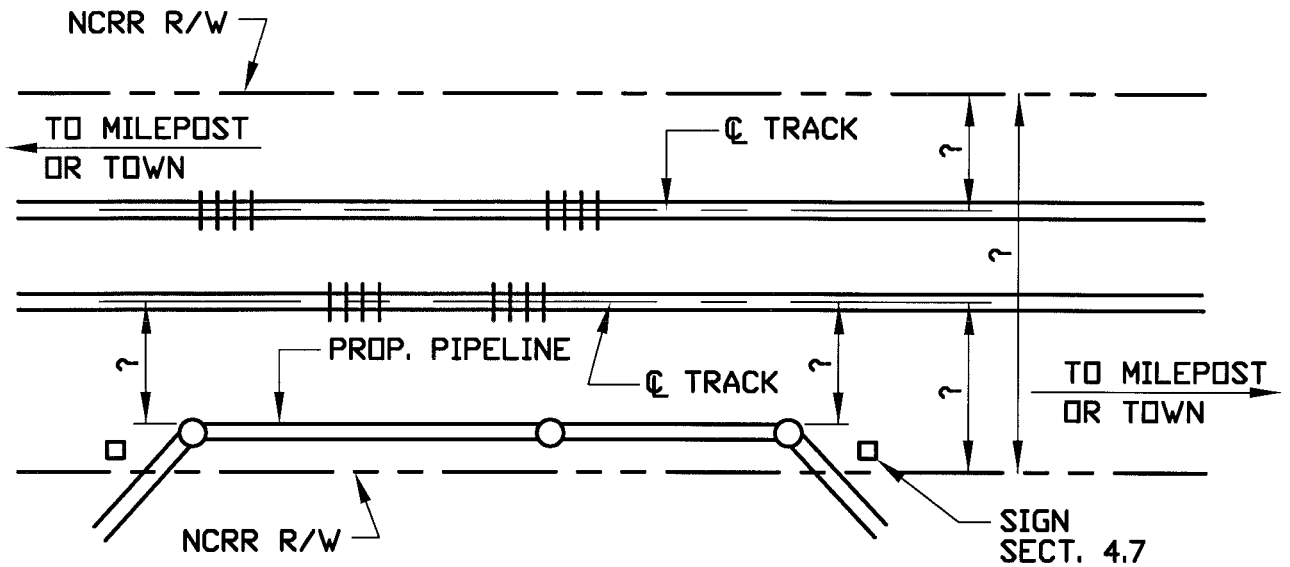

PLAN - SEE SECT. 1.6
SCALE OF DRAWING TO BE SHOWN

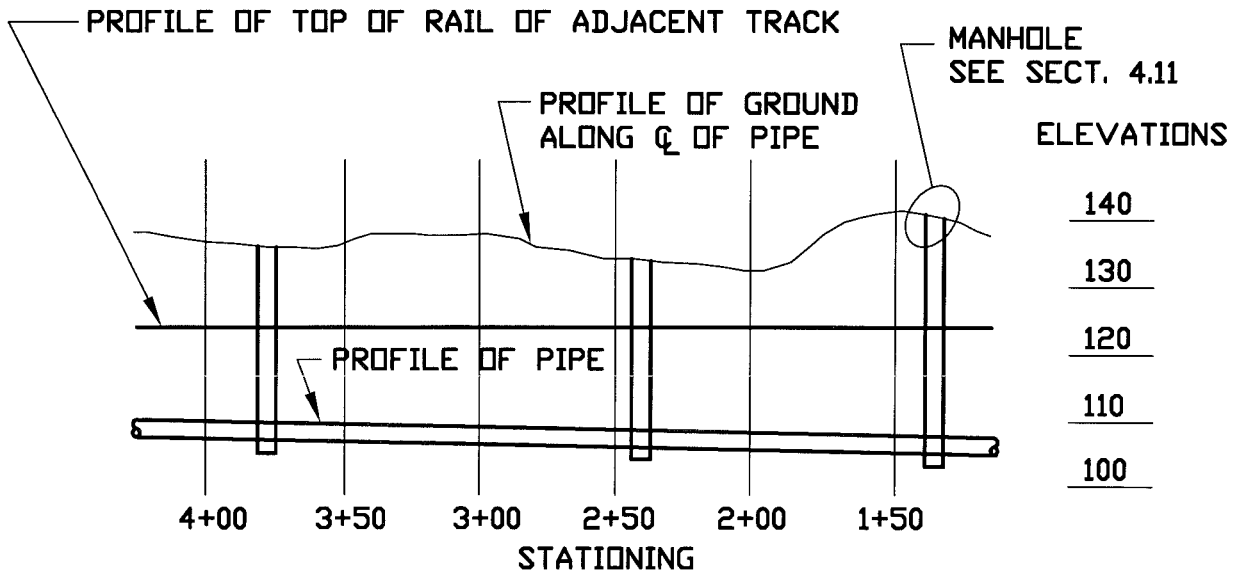

PROFILE - SEE SECT. 1.6
SCALE: HORIZ: _____
VERT: _____

PLATE V

LONGITUDINAL OCCUPANCY

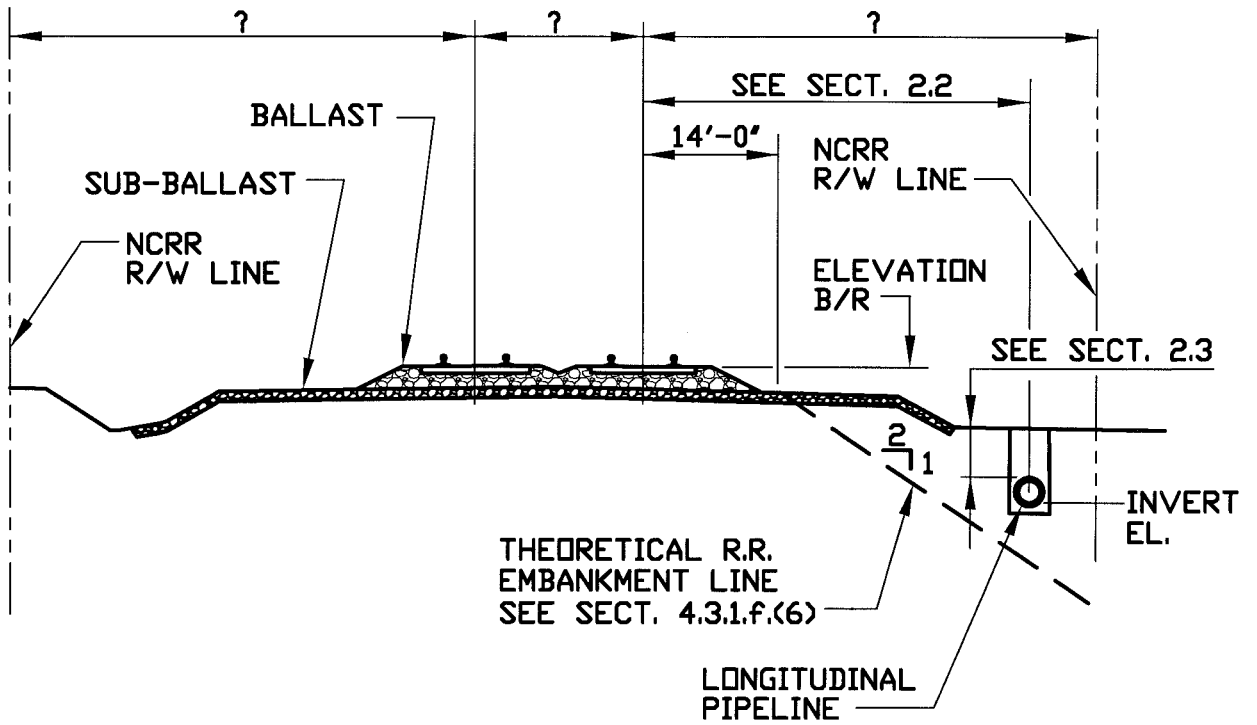

SECTION

SCALE OF DRAWING TO BE SHOWN

NOTE: SECTIONS TO BE TAKEN EVERY 500 FEET MAXIMUM.

PLATE VI

PIPELINE IN HIGHWAY UNDER RAILROAD BRIDGE

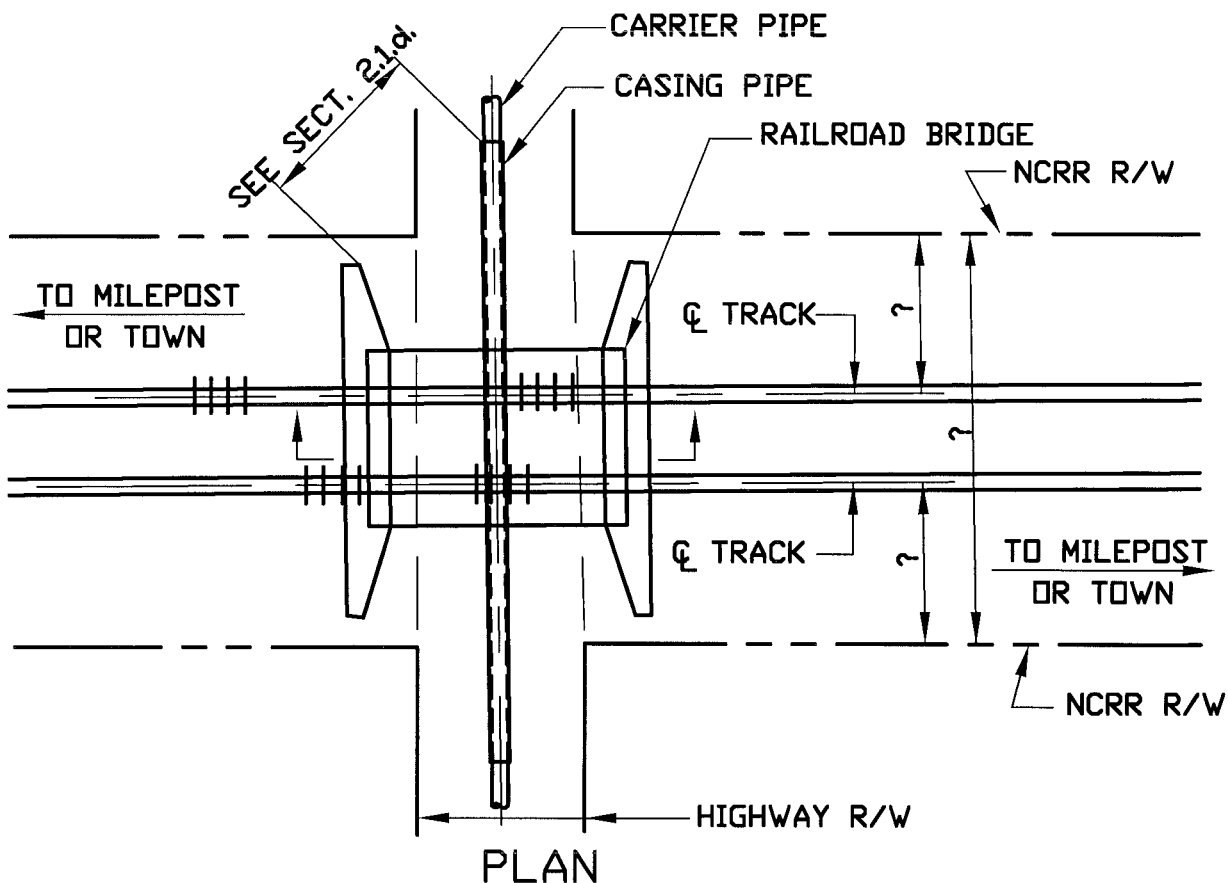

SCALE OF THE DRAWING TO BE SHOWN

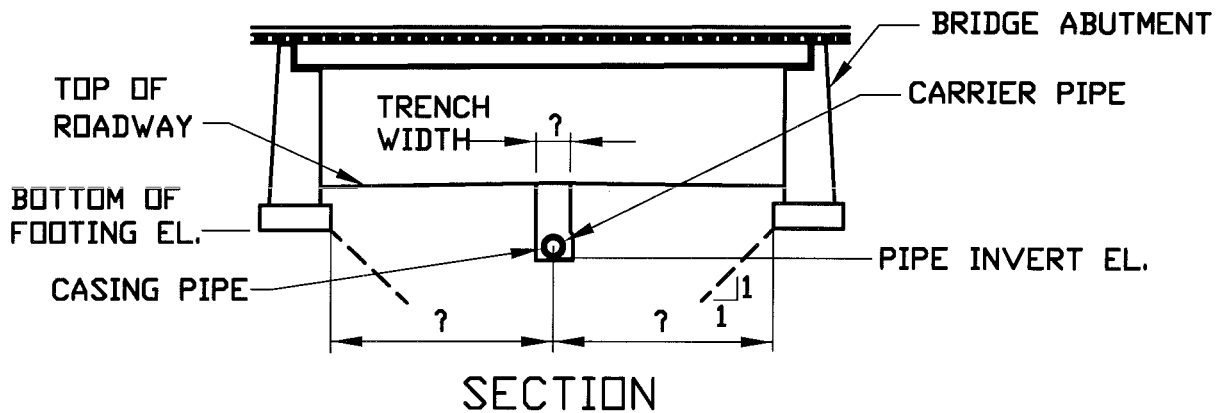

SCALE OF THE DRAWING TO BE SHOWN

NOTE: PIPE OR EXCAVATION MUST NOT BE WITHIN THE 1 TO 1 SLOPE LINE THAT EXTENDS FROM BOTTOM OF FOOTING.

PLATE VII

PIPELINE ON HIGHWAY BRIDGE OVER RAILROAD

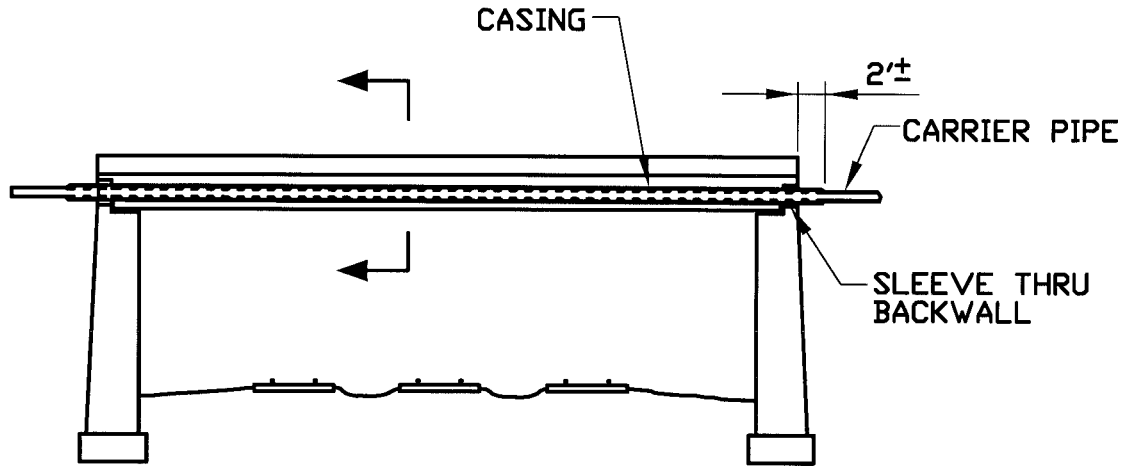

ELEVATION

SCALE OF THE DRAWING TO BE SHOWN

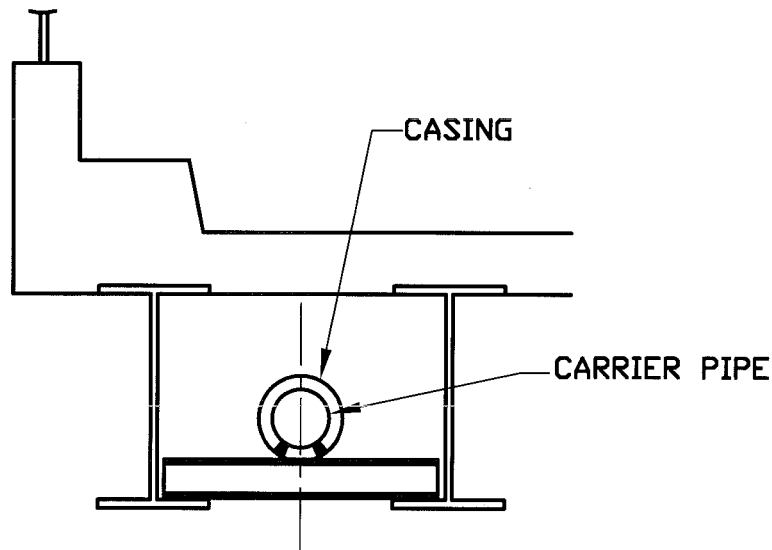

SECTION

SCALE OF THE DRAWING TO BE SHOWN

PLATE IX
LATERAL PRESSURE DIAGRAM

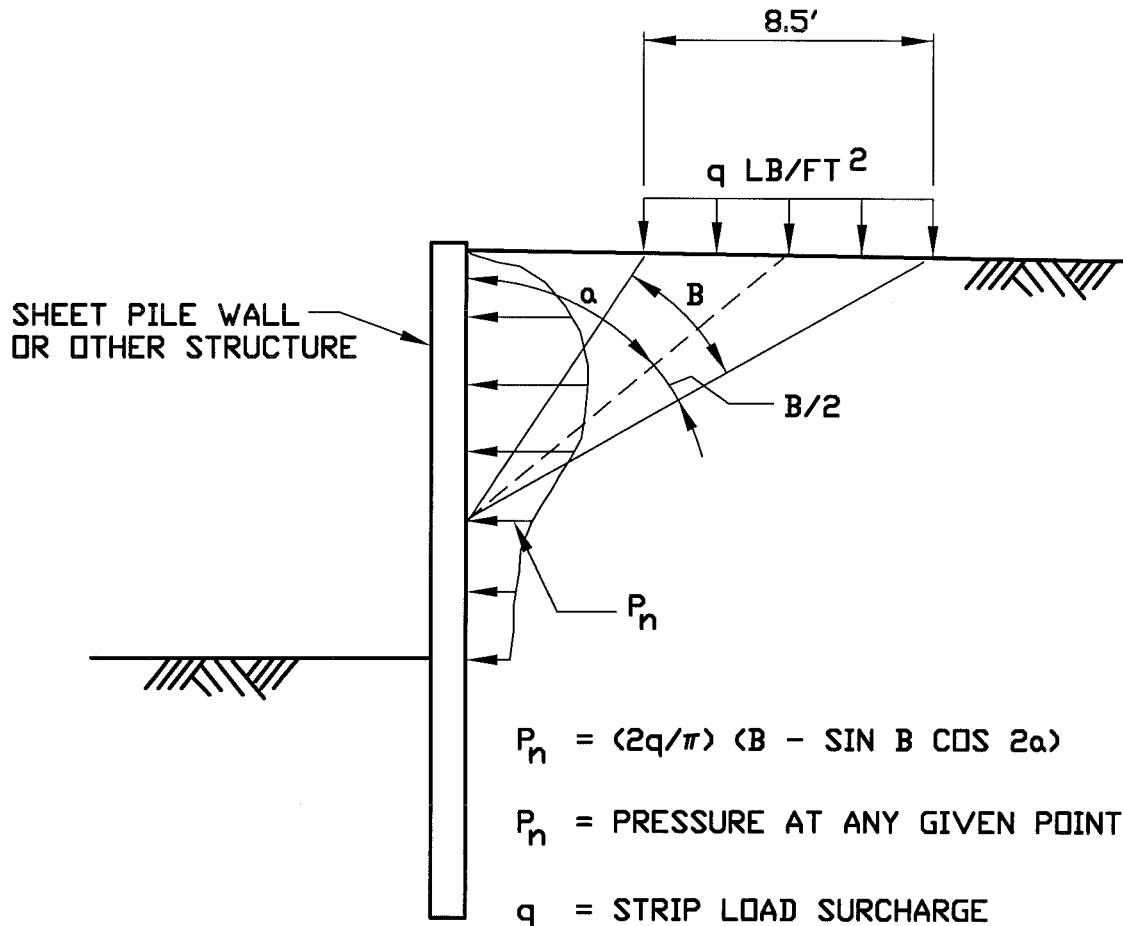

ELEVATION

LATERAL PRESSURE DUE TO STRIP LOAD

PLATE X
FOLDING OF PLANS

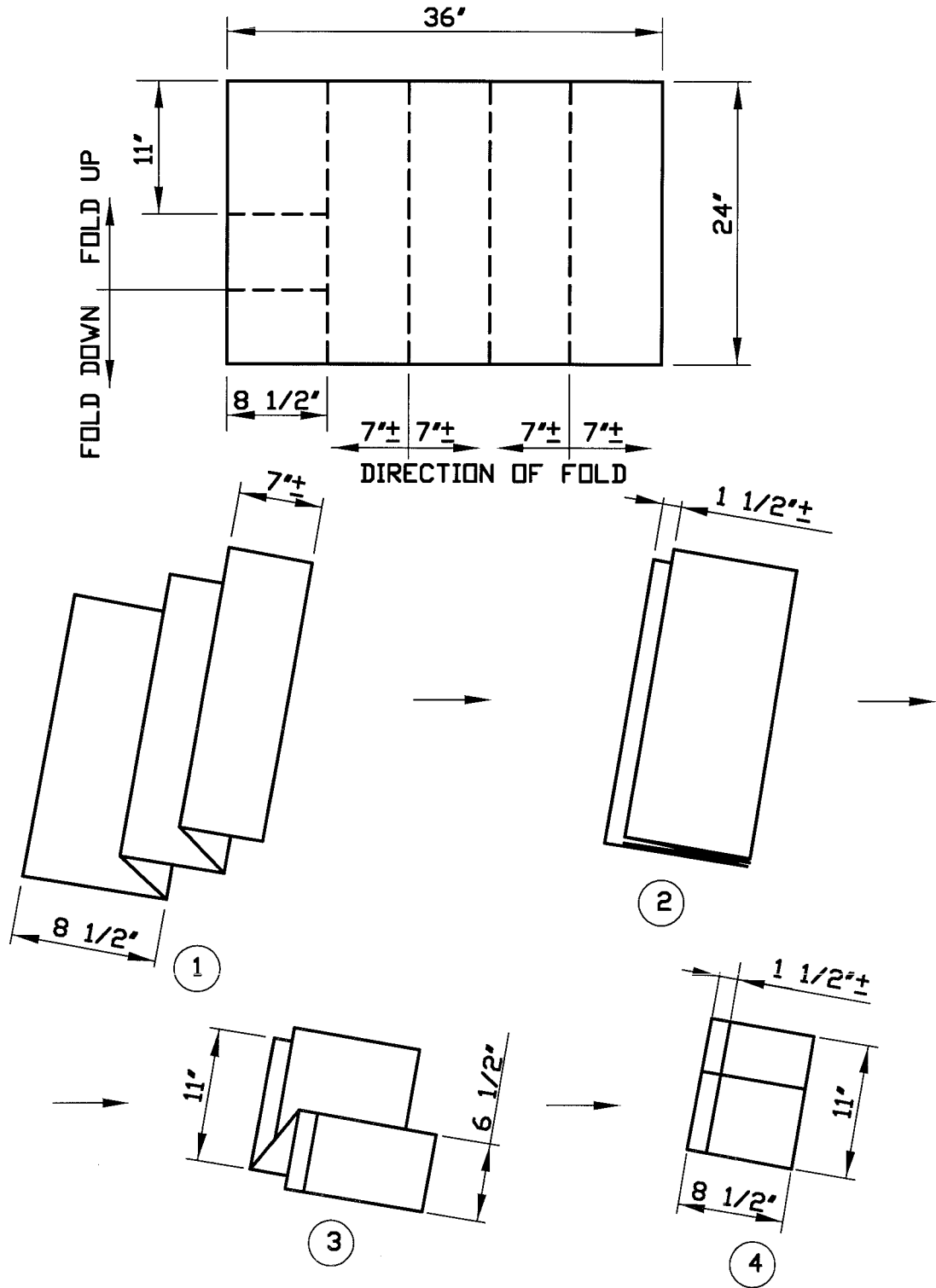
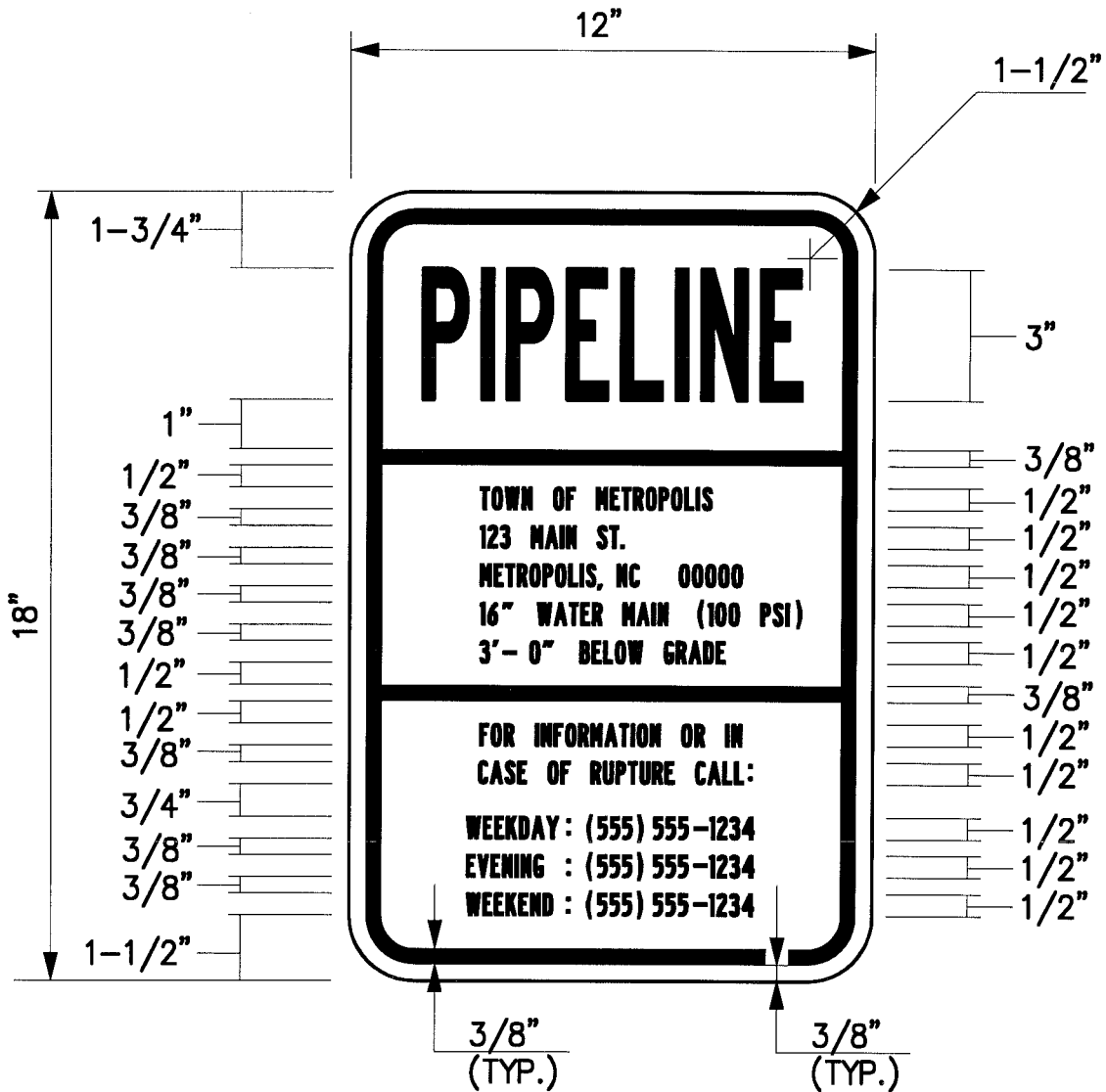

PLATE XI
SAMPLE WEATHERPROOF SIGN



SIGN DATA:

- 1/8" ALUMINUM PANEL
- 3M SCOTCH LITE "ENGINEER GRADE" SHEETING OR APPROVED EQUAL.
- RED COPY ON WHITE BACKGROUND
- MOUNT SIGN PANEL 5' ABOVE GRADE (MIN.)
- USE 2 LB/FT U-CHANNEL POST (MIN.)
- MOUNT SIGNS BACK-TO-BACK ON POST.

PUBLICATION STANDARDS SOURCES

- ANSI American National Standards Institute, Inc.
25 West 43rd Street
New York, NY 10018
(212) 642-4900
- AREMA American Railway Engineering and Maintenance of Way Association
8201 Corporate Drive
Landover, MD 20785
(301) 459-3200
- ASTM American Society for Testing and Materials
100 Barr Harbor Drive
West Conshohocken, PA 19428
(610) 832-9585
- AWWA American Water Works Association, Inc.
6666 West Quincy Avenue
Denver, CO 80235
(303) 794-7711
- The National Association of Corrosion Engineers
1440 South Creek Drive
Houston, TX 77084
(281) 228-6200

NOTE: If other than AREMA specifications are referred to for design, materials or workmanship on the plans and specifications for the work, then copies of the applicable sections of such other specifications referred to shall accompany the plans and specifications for the work.